

**(DEE 411)**

**B.Tech. DEGREE EXAMINATION, DECEMBER – 2015**

**(Examination at the end of Fourth Year First Semester)**

**ELECTRICALS & ELECTRONICS ENGINEERING**

**Paper – I : Industrial Management**

**Time : 3 Hours**

**Maximum Marks: 75**

---

**Answer any five questions**

**All questions carry equal marks**

- 1) State the principles of scientific management.
- 2) What are the functions of personnel management?
- 3) Explain the features of partnership firm.
- 4) How are simple and compound interest computed?
- 5) Describe the merits and demerits of straight line method of depreciation.
- 6) Discuss the steps involved in production planning and control.
- 7) Explain the evaluation of reliability.
- 8) Describe the process of selecting vendors.
- 9) Give an account of carrying and not carrying costs.
- 10) Bring out the techniques used to promote sales.

*EEE*

**B. Tech. DEGREE EXAMINATION, DECEMBER – 2015**

**(Examination at the end of IVth Year First Semester)**

**ELECTRICALS & ELECTRONICS ENGINEERING**

**Paper –II : Power Systems Operation and Control**

**Time : 3 Hours**

**Maximum Marks: 75**

---

*Answer question No.1 is compulsory*

*(15)*

*Answer one question from each unit*

*(4×15 = 60)*

- 1) a) What is control area?
- b) Write the expression for incremental fuel cost.
- c) What are B- coefficients?
- d) Draw heat rate curve.
- e) What are the factors which influence the dynamic response of a turbine?
- f) What is free governor operation?
- g) Define Area Control Error.
- h) What is the function of error amplifier in an AVR?
- i) Draw the block diagram of generator model in an AVR?
- j) List any two shunt compensating devices.
- k) What are the disadvantages of SVCs?
- l) List out the applications of FACTS devices.
- m) What are the advantages of static capacitors?

- n) What is the main function of power system control center?
- o) What is the role of energy management in power systems?

### UNIT - I

- 2) Incremental fuel costs in rupees per Megawatt hour for two units are given by  $\frac{dF_1}{dP_1} = 0.1P_1 + 20$  &  $\frac{dF_2}{dP_2} = 0.12P_2 + 10$ , the maximum and minimum loads on each unit are to 25MW and 120 MW respectively. Determine the incremental fuel cost and the allocation of load between units for minimum cost when the loads are
- a) 100MW
  - b) 150MW

OR

- 3) a) Derive the condition for optimal allocation of total load among units in a thermal station when losses are neglected.
- b) Discuss and define the loss formula coefficients. Also state assumptions made.

### UNIT - II

- 4) a) Explain the concept of control area in a load control problem.
- b) Two synchronous generators operate in parallel and supply a total load of 400MW, the capacities of machines are 200 MW and 500 MW and both have generator droop characteristics of 4% from no load to full load. Calculate the load taken by each machine. Assume free governor operation. Also find system frequency at this load.

OR

- 5) With a neat block diagram, explain the steady state analysis of an isolated power system.

### UNIT - III

- 6) Explain clearly what do you mean by compensation of a line and discuss briefly different methods of compensation.

OR

- 7) a) Explain the role of excitation system in reactive power control of synchronous generators.
- b) Obtain the simplified block diagram for automatic Voltage Regulator.

**UNIT - IV**

- 8) Discuss about the hardware and software technologies in power system control center.

OR

- 9) Explain briefly the dispatch training and activities of the power system control center with the functioning of the simulator.

*EEE*

**(DEE 413)**

**B. Tech. DEGREE EXAMINATION, DECEMBER – 2015**

**(Examination at the end of Fourth Year First Semester)**

**ELECTRICALS & ELECTRONICS ENGINEERING**

**Paper –III : Industrial Drives**

**Time : 3 Hours**

**Maximum Marks: 75**

---

**Answer question No.1 is compulsory**

**(15)**

**Answer any one question from each unit**

**(4×15 = 60)**

**1) Write briefly on the following:**

- a) What is electric drive.
- b) What is cyclo converter.
- c) Why is starting method required for DC motor.
- d) Explain the rectifier control.
- e) Define role amplitude modulation.
- f) Explain Eddy current drives.
- g) Explain slip power recovery.
- h) List out the advantages of Ward – Leonard schemes.
- i) What is the expression for slip power.
- j) Give the applications of variable reluctance motor.
- k) What are the armature voltage control methods.
- l) Classify load torques.
- m) What is the advantage of multi quadrant operation.

- n) What are the components of electric drive.
- o) Explain the rectifier control.

**UNIT - I**

- 2) Explain in detail about the multi quadrant operation of electric drives using proper analogy.

OR

- 3) Explain in detail about characteristics of different types of loads.

**UNIT - II**

- 4) a) A 200V, 10.5A, 2000 rpm shunt motor has the armature and field resistance of  $0.5\Omega$  and  $400\Omega$  respectively. It drives a load whose torque is constant at rated motor torque. Calculate motor speed if the source voltage drops to 170V.

- b) Explain the methods of armature voltage control.

OR

- 5) a) Briefly discuss the comparison of conventional and static Ward –Leonard schemes.
- b) Explain the rectifier control of dc series motor.

**UNIT - III**

- 6) a) Discuss any three starting methods of induction motor drives.
- b) Explain stator voltage control.

OR

- 7) Compare CSI and VSI drives.

**UNIT - IV**

- 8) Draw the block diagram of a closed loop synchronous motor drive fed from VSI and explain.

OR

- 9) Describe separate controlled mode and self controlled mode of operation of a synchronous motor drive in detail and compare them.

*EEE*

**B. Tech. DEGREE EXAMINATION, DECEMBER – 2015**

**(Examination at the end of Fourth Year First Semester)**

**ELECTRICALS & ELECTRONICS ENGINEERING**

**Paper –IV : Power Systems Analysis & Stability**

**Time : 3 Hours**

**Maximum Marks: 75**

---

*Answer question No.1 is compulsory*

*(15)*

*Answer one question from each unit*

*(4×15 = 60)*

- 1) a) What is the advantage of p.u value over percent value?
- b) What are the advantages of representing all parameters in p.u values?
- c) What is one line diagram?
- d) Give the applications of impedance diagram.
- e) What is the limitation for direct inspection method.
- f) What are the methods used for reducing short circuit current?
- g) What are the reasons for faults occurrence in power systems?
- h) Define negative sequence impedance.
- i) When the system is said to be unbalanced?
- j) Define transient stability.
- k) When does maximum power transfer occur in a short line with resistance and reactance only.
- l) What are the causes for large disturbances in the system?

- m) What are the new methods of improving transient stability?
- n) Give typical values for inertia constant H of various machines.
- o) Define critical clearing angle.

**UNIT - I**

- 2) a) What are the assumptions made in constructions the reactance diagram of an interconnected network. Also explain the procedure for constructions reactance diagram.
- b) A 1- $\phi$  transformer of 11kV/400V, 50Hz 150 kVA has primary resistance and reactances are  $2\Omega$  and  $10\Omega$ , the secondary resistance and reactances are  $0.01\Omega$  and  $0.05\Omega$  respectively. Determine the p.u values of transformer.

OR

- 3) The one line diagram of an unloaded power system is shown below. Reactances of two sections of transmission line are shown on the diagram. The generators and transformers are rated as follows:

Generator 1: 20 MVA, 13.8 kV,  $X^{11} = 0.20$  pu

Generator 2: 30 MVA, 18 kV,  $X^{11} = 0.20$  pu

Generator 3: 30 MVA, 20 kV,  $X^{11} = 0.20$  pu

Transformer  $T_1$ : 25MVA, 220/13.8 kV Y -  $\Delta$  ,  $X = 10\%$

Transformer  $T_2$ : 1- $\phi$  units each rated 10 MVA, 127/18 kV,  $X = 10\%$

Transformer  $T_3$ : 35 MVA, 220/22 kV, Y-Y,  $X = 10\%$

Draw the impedance diagram with all reactances marked in per unit. Choose base of 50 MVA, 13.2 kV in the circuit of generator1.

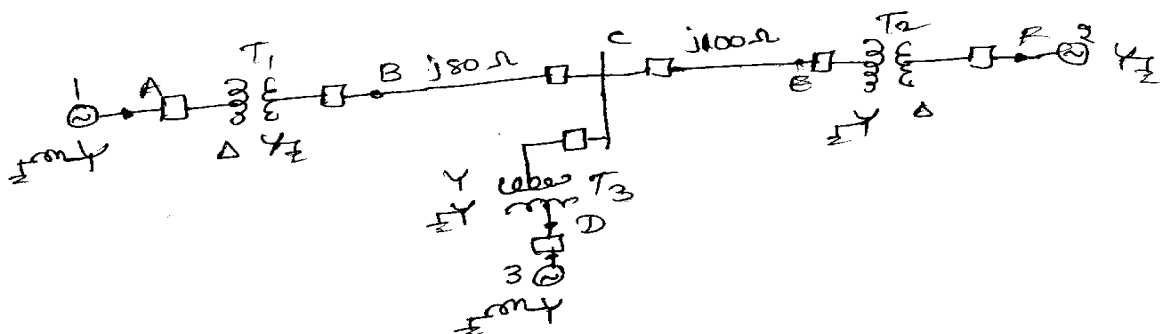



## UNIT - II

- 4) a) What is load flow problem? Discuss the procedure for obtaining approximate load flow solution from the basic static load flow equations.
- b) Why direct simulation of load flow is not possible? Also mention the data required for load flow solution.

OR

- 5) Two generators are connected to a common bus bar, at which an outgoing feeder is connected. The generator ratings are 15MVA, 30% and 20 MVA, 50% respectively. The percentage reactance of each alternator is based on its own capacity. The busbar voltage is 12kV. Find the short circuit current that will flow into a complete 3- $\phi$  short circuit at the beginning of the outgoing feeder.

## UNIT - III

- 6) a) An L-G fault occurs at point F on the systems shown in figure. Find fault current

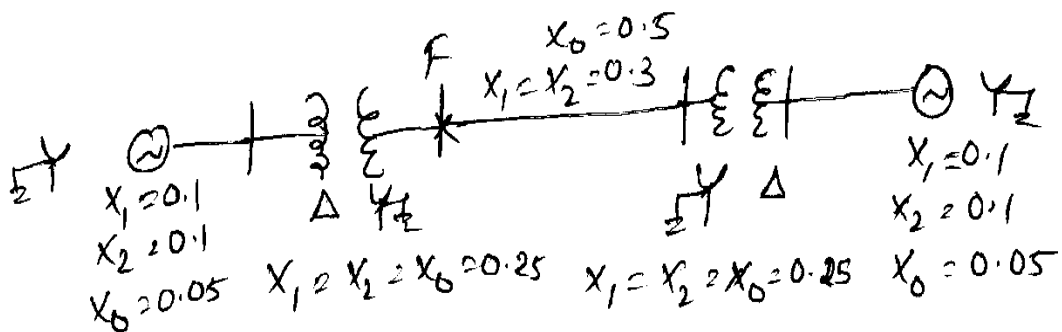

- b) What are the different unsymmetrical faults and compare their characteristics.

OR

- 7) a) Draw the positive, negative and zero sequence impedance diagrams for different 3- $\phi$  transformer winding connections.
- b)  $P_{abc}$  is 3- $\phi$  power in a circuit and  $P_{012}$  is power in the same circuit in terms of symmetrical components. Show that  $P_{abc} = 3 P_{012}$ .

## UNIT - IV

- 8) a) Explain transfer reactance and inertia constant.
- b) Define synchronising power coefficient and explain its significance.

OR

- 9) What is equal area criterion? Explain its significance and applications.

*EEE*

**(DEE 415)**

**B. Tech. DEGREE EXAMINATION, DECEMBER – 2015**

**(Examination at the end of Fourth Year First Semester)**

**ELECTRICALS & ELECTRONICS ENGINEERING**

**Paper –V : Electrical Machine Design**

**Time : 3 Hours**

**Maximum Marks: 75**

---

**Answer question No.1 is compulsory (15)**

**Answer any one question from each unit (4×15 = 60)**

- 1) a) Write the expression for output coefficient in a D.C machine.
- b) List any two advantages of having large number of poles.
- c) What are the factors that affect choice of number of poles.
- d) What is the expression for power developed by armature in a DC machine?
- e) What is the maximum value of slot loading in a DC machine?
- f) What are the quantities that are to be designed minimum for optimum design of a transformer?
- g) Write expression for gross core area of a transformer?
- h) What are various types of high voltage windings in a transformer?
- i) What is relation between L and T?
- j) What are the factors to be considered for estimation of length of air gap?
- k) Define short circuit ratio?
- l) What is skewing?

- m) What are the typical values of  $B_{au}$  and  $a_c$  in the design of turbo alternators.
- n) What are the limiting factors to the width of rotor slots?
- o) State any two advantages of computer aided design.

### UNIT - I

- 2) a) Discuss the factors affecting the choice of average gap density and ampere conductors per metre in detail.
- b) Explain the procedure for designing the field system in a DC machine.

OR

- 3) A shunt field coil has to develop an mmf of 9000A. The voltage drop in the coil is 40v, and the resistivity of round wire used is  $0.021 \Omega/\text{m}$  and  $\text{mm}^2$ . The depth of winding is 35 mm approximately and the length of mean turn is 1.4 m. Design a coil so that the power dissipated is  $700 \text{ w/m}^2$  of the total coil surface (in outer, inner, top and bottom). Take the diameter of the insulated wire 0.2 mm greater than that of bar wire.

### UNIT - II

- 4) Derive the conditions for minimum cost and minimum loss in the design of transformers.

OR

- 5) a) Discuss about the design of yoke and overall dimensions in a transformer.
- b) The ratio of flux to full load mmf in a 400KVA 50Hz, 1- $\phi$  core type power transformer is  $2.4 \times 10^{-6}$ . Calculate the net iron area and the window area of the transformer. Maximum flux density in the core is  $1.3 \text{ wb/m}^2$ , current density  $2.7 \text{ A/mm}^2$  and window space factor is 0.26. Also calculate the full load mmf.

### UNIT - III

- 6) Determine the main dimensions, turns per phase, number of slots, conductor cross section and slot area of 250 Horse power, 3- $\phi$ , 50Hz, 400v, 1410 rpm slip ring induction motor. Assume  $B_{au} = 0.5 \text{ wb/m}^2$ ,  $a_c = 30,000 \text{ A/m}$ , efficiency=0.9 and power factor =0.9 winding

factor = 0.955, current density =  $3.5 \text{ A/mm}^2$ . The slot space factor is 0.4 and the ratio of core length to pole pitch is 1.2. The machine is delta connected.

OR

- 7) a) What are the rules to be followed in selecting the rotor slots in induction motors.  
b) Discuss about the design of wound rotor in the induction motors.

#### UNIT - IV

- 8) a) Derive the output equation of synchronous machine.  
b) Explain the procedure for designing the rotor of cylindrical rotor alternator.

OR

- 9) a) Determine the main dimensions of a 75000 KVA, 13.8 KV, 50Hz, 62.5 rpm, 3- $\phi$  star connected alternator also find the number of stator slots, conductors per slot conductor area and work out the winding details. The peripheral speed should be about 40 m/s. Assume average gap density =  $0.65 \text{ wb/m}^2$  ampere conductors per metre = 40,000 and current density =  $4 \text{ A/mm}^2$ .  
b) Discuss the advantages of computer aided design.

*EEE*

**(DEE 416 B)**

**B.Tech. DEGREE EXAMINATION, DECEMBER – 2015**

**(Examination at the end of Fourth Year First Semester)**

**ELECTRICALS AND ELECTRONICS ENGINEERING**

**Paper – VI : HVDC Transmission**

**Time : 3 Hours**

**Maximum Marks: 75**

---

**Answer Question No.1 is compulsory**

**( 15)**

**Answer one question from each unit**

**(4×15 =60)**

**1) Write briefly on the following**

- a) What is a graetz circuit?
- b) Mention the use of smoothing reactor in DC line.
- c) Mention any one technical advantage of HVDC over AC line.
- d) List out two disadvantages of DC transmission line.
- e) Define SCR.
- f) Define Telephone influence factor.
- g) Why non-characteristic harmonics come into existence?
- h) Why current margin is required in HVDC transmission?
- i) What is meant by commutation failure in Inverters?
- j) What is the function of surge arrester?
- k) What is the need of reactive power control in converters?
- l) What is the order of AC current harmonics?

- m) How effectiveness of DC filter is judged? Mention any one reason.
- n) How smoothing reactors and converters are modelled in DC Network?
- o) What are the different types of equidistant pulse controls?

### UNIT - I

- 2) a) Compare AC and DC transmission systems in terms of technical performance.
- b) What are the applications of DC transmission? Explain.

OR

- 3) a) What are components of a converter station? Explain with sketches.
- b) Explain different asynchronous interconnections used in HVDC.

### UNIT - II

- 4) a) Derive the expression for DC voltage with overlap angle.
- b) Draw and explain converter bridge characteristics.

OR

- 5) a) How protection against over currents are carried out? Explain .
- b) What are the different types of converter faults? Explain any two of them.

### UNIT - III

- 6) a) Draw and explain converter control characteristics? How they are modified.
- b) Explain current and extinction angle control in converters.

OR

- 7) a) What are the reactive power requirements in steady state? Explain.
- b) How reactive power is controlled? Explain any one method of control.

## UNIT – IV

- 8) a) How calculation of voltage and current harmonics are carried? Explain.  
b) On what basis DC filters are designed? Explain.

OR

- 9) a) How DC network is modelled for power flow analysis? Explain with equations.  
b) Explain the design of high pass filter.





**(DEE 416 D)**

**B.Tech. DEGREE EXAMINATION, DECEMBER – 2015**

**(Examination at the end of Fourth Year First Semester)**

**ELECTRICALS AND ELECTRONICS Engineering**

**Paper - VI : Fuzzy Logic and Application**

**Time : 3 Hours**

**Maximum Marks: 75**

---

**Question No.1 is compulsory**

**(15)**

**Answer one question from each unit**

**(4×15 = 60)**

- 1) a) Define sets and subsets.
- b) List the properties of crisp sets.
- c) What are the fuzzy set operations.
- d) What is membership function.
- e) Define Defuzzification.
- f) What is a crisp relation.
- g) Define fuzzification.
- h) List some fuzzy rules.

**UNIT - I**

- 2) a) Explain with example operations and properties of crisp relations.
- b) Write short notes on tolerance and equivalence relations.

OR

- 3) a) Explain fuzzy set operations with an example.
- b) Discuss properties of crisp relations.

## UNIT - II

- 4) a) Explain different membership functions.  
b) Write short notes on fuzzy vectors.

OR

- 5) a) Explain DSW algorithm.  
b) Write short notes on genetic algorithms and list its applications.

## UNIT - III

- 6) a) Explain fuzzy logic and approximate reasoning.  
b) Write short notes on linguistic Hedges.

OR

- 7) a) Explain aggregation of fuzzy rules.  
b) Discuss canonical rule forms.

## UNIT - IV

- 8) a) Explain C-means clustering.  
b) Discuss about fuzzy synthetic evaluation.

OR

- 9) a) Explain fuzzy Bayesian decision method.  
a) Write short notes on clustering with an example.



**(DEE 421)**

**B.Tech. DEGREE EXAMINATION, DECEMBER – 2015**

**(Examination at the end of Fourth Year Sixth Semester)**

**ELECTRICALS & ELECTRONICS ENGINEERING**

**Paper - I : Electrical Power Distribution System Engineering**

**Time : 3 Hours**

**Maximum Marks: 75**

---

**Answer Question No.1 is compulsory**

**(15)**

**Answer ONE question from each unit**

**(4×15 = 60)**

- 1) a) Define loss factor.
- b) Define power factor.
- c) What is transformer load management?
- d) Define voltage regulation.
- e) What is distribution system?
- f) Define coincidence factor.
- g) Explain quality of service.
- h) Define express feeder.
- i) Define Line Drop compensation.
- j) What is DAC? Explain its function.
- k) Define automatic circuit recloser.
- l) Write the expression for percent power loss.
- m) Define efficiency.

- n) List different types of outdoor transformers.
- o) What is primary system?

### **UNIT - I**

- 2) a) Explain the various factors affecting the distribution system planning.
- b) Discuss the effect of load factor on the cost of generation in a power system.

OR

- 3) Draw a schematic single line diagram of the electrical power system and explain its typical parts in detail.

### **UNIT - II**

- 4) a) Explain the various types of distribution transformer.
- b) Explain the use of monograms for obtaining efficiency of distribution transformer.

OR

- 5) a) Explain about KW-KVA method of determining regulation of a distribution transformer.
- b) Explain about different types of distribution transformer.

### **UNIT - III**

- 6) What are the various factors that are to be considered in selecting a primary feeder rating. Describe the arrangement with suitable diagram.

OR

- 7) a) Explain any two co-ordination protective schemes.
- b) Write short notes on the following:
  - i) Automatic circuit reclosers.
  - ii) Automatic circuit breaker.

## UNIT - IV

- 8) a) Discuss the loss reduction and voltage improvement in rural distribution networks in detail.
- b) Derive the expressions for voltage drop and power loss in 3 $\phi$  primary lines.

OR

- 9) Write short notes on:
- a) Power factor correction.
- b) Cone drop compensation.



**(DEE 422)**

**B.Tech. DEGREE EXAMINATION, DECEMBER – 2015**

**(Examination at the end of Fourth Year Sixth Semester)**

**ELECTRICALS & ELECTRONICS ENGINEERING**

**Paper - II : High Voltage Engineering**

**Time : 3 Hours**

**Maximum Marks: 75**

---

**Answer Question No.1 is compulsory**

**(15)**

**Answer ONE question from each unit**

**(4×15 = 60)**

- 1) a) What is impulse generation?
- b) What is the purpose of resonant transformer?
- c) Draw the circuit for voltage divider.
- d) What is sphere gap?
- e) What is the principle of peak voltmeter?
- f) What is the technique used for testing of transformer?
- g) What is finite different method?
- h) Which is the most suitable numerical method for electric field computation?
- i) What is flash over?
- j) What are the causes for switching surges?
- k) What are the disadvantages of spark gap surge diverter?
- l) How are the testing of insulators classified?
- m) Define Tesla coil.

- n) Define Marx circuit.
- o) Define chopped wave.

### **UNIT - I**

- 2) a) Explain with neat diagram triggering and synchronization of the impulse generator with the CRO.
- b) Describe the various components used in the development of an impulse generator.

OR

- 3) a) Derive an expression for voltage efficiency of a single stage impulse generator.
- b) Describe the principle of operation of Cockcroft-Walton cascade arrangement.

### **UNIT - II**

- 4) a) Why capacitance voltage dividers preferred for high ac voltage measurements?
- b) What are the conditions to be satisfied by a potential divider to be used for impulse work?

OR

- 5) Write short notes on:
  - a) Sphere gap.
  - b) Peak voltmeter.
  - c) Voltage divider.

### **UNIT - III**

- 6) Explain the testing techniques of insulators, bushings and isolators.

OR

- 7) a) Discuss the testing of transformers in detail.
- b) Explain how the fault detection is carried out by using wavelets.

## UNIT - IV

8) Explain about the finit difference method with suitable equations.

OR

9) Explain the charges simulation methods in detail.





**B.Tech. DEGREE EXAMINATION, DECEMBER – 2015**

**(Examination at the end of Final Year)**

**ELECTRICALS AND ELECTRONICS ENGINEERING**

**Paper - III : Computer Aided Power System Analysis**

**Time : 3 Hours**

**Maximum Marks: 75**

---

**Answer Question No.1 is compulsory**

**(15)**

**Answer ONE question from each unit**

**(4×15 = 60)**

- 1) a) What is orthogonal matrix?
- b) What is sparsity of a matrix?
- c) State the advantages of voltage dividers.
- d) Write the expression for symmetrical short circuit current.
- e) Define directed graph.
- f) What is basic cut-set?
- g) Write the expression for  $Z_{bus}$ .
- h) What is the function of CB?
- i) Define critical clearing angle.
- j) Write Swing equation.
- k) Define chopped wave.
- l) State KVL.
- m) Define load flow solution.

- n) What is transient stability.
- o) What are symmetrical components?

### UNIT - I

- 2) a) Derive loop admittance matrix from augmented networks admittance matrix.
- b) Derive the  $[Z_{bus}] = A^T[Y]A^{-1}$  by singular transformation.

OR

- 3) a) Derive the bus admittance matrix by singular transformation.
- b) Derive Branch impedance matrix from augmented impedance matrix.

### UNIT - II

- 4) a) Explain the representation of 3- $\phi$  network elements for unbalanced systems.
- b) Briefly explain fault level of a bus. Justify infinite bus as a constant voltage source.

OR

- 5) a) Explain the concept of mutually coupled branches in  $Z_{bus}$ .
- b) Two motors each of IMUA at 440 volts with 0.1 pu transient reactance are connected in parallel. The motors are fed over a short line of reactance  $0.05\Omega$ . This line is supplied from a large system whose short circuit MVA is 8 on 440 volts rating. If a 3 $\phi$  short circuit occurs at the terminals of motors. Calculate the short circuit current fed into the fault.

### UNIT - III

- 6) a) Describe Newton Raphson method in polar co-ordinates.
- b) Explain Gauss iterative method with a flow chart.

OR

- 7) a) Compare different load flow methods.
- b) Define Acceleration factor and write the algorithm for Gauss-Seidal method when PV bus is absent.

#### UNIT - IV

- 8) a) State the assumptions made on the transient stability solution techniques.
- b) Explain the representation of synchronous machine by constant voltage behind transient reactance and network by steady state equations.

OR

- 9) Write a short note on:
- a) Boundary element method.
- b) Dynamic stability limit.
- c) Critical clearing time.
- d) Infinite bus.



**(DEE 424 A)**

**B.Tech. DEGREE EXAMINATION, DECEMBER – 2015**

**(Examination at the end of Fourth Year Sixth Semester)**

**ELECTRICALS & ELECTRONICS ENGINEERING**

**Paper - IV : Embedded Systems & VLSI**

**Time : 3 Hours**

**Maximum Marks: 75**

---

**Answer Question No.1 is compulsory (15)**

**Answer ONE question from each unit (4×15 = 60)**

- 1) a) What is parallelism in general purpose processors?
- b) Write any three characteristics of embedded systems.
- c) Define area capacitance.
- d) Define threshold voltage of a MOS device.
- e) How the clocks are selected in PLA?
- f) Differentiate design capture tools and design verification tools.
- g) Define synthesis & simulation.
- h) What is path delay?
- i) Define intellectual property coder.
- j) What is an ASIC, give examples?

**UNIT - I**

- 2) a) Explain why single-purpose processors and general purpose processors are essentially the same, and then describe how they differ in terms of design metrics.
- b) Compare an ASIP from a micro controller and a digital signal processor.

OR

- 3) a) List and define three main processor technologies. What are the benefits in each of the three different processor technologies?
- b) Explain the concept of pipelining with example.

**UNIT - II**

- 4) a) Explain how a bipolar npn transistor is included in n-well CMOS processing. Draw the cross section of Bi-CMOS transistor.
- b) Bring out the effects of scaling on the following parameters in all the scaling models.
- i) Gate capacitance.
  - ii) Maximum operating frequency.
  - iii) Power speed product.

OR

- 5) a) How are the shortcomings of CMOS technology overcome through Bi-CMOS technology?
- b) Explain different types of scaling models. Write down scaling factors used for these models.

**UNIT - III**

- 6) a) Discuss about
- i) path delay
  - ii) Transistor sizing with respect to combinational network delay.
- b) What are the different types of programmable inter connection channels used for routing parts in FPGAs? Explain.

OR

- 7) a) Discuss about power optimization in logic networks.
- b) Compare and contrast standard cell design with gate array architecture.

#### UNIT - IV

- 8) a) Explain about Hardware / Software co-simulation.
- b) Discuss about:
- i) Logic synthesis.
  - ii) RT synthesis.

OR

- 9) a) Explain about reuse of intellectual property codes.
- b) Discuss about the design methodology for IBM ASICS.



**(DEE 424 B)**

**B.Tech. DEGREE EXAMINATION, DECEMBER – 2015**

**(Examination at the end of Fourth Year Sixth Semester)**

**ELECTRICALS & ELECTRONICS ENGINEERING**

**Paper - IV : Artificial Neural Networks**

**Time : 3 Hours**

**Maximum Marks: 75**

---

**Answer Question No.1 is compulsory**

**(15)**

**Answer ONE question from each unit**

**(4×15 = 60)**

- 1) a) What is a neuron?
- b) What is activation function?
- c) State perceptron convergence theorem.
- d) What is supervised rule?
- e) What is delta learning rule?
- f) What is ADALINE?
- g) What is Hebbian rule?
- h) Draw a single layer feed forward network.

**UNIT - I**

- 2) a) Explain the memory based learning.
- b) Explain stepwise how learning without a teacher adaptation is done.

OR

- 3) a) Discuss different network architectures.
- b) Write short notes on Hebbian learning.

## UNIT - II

- 4) a) Write short notes on annealing techniques.  
b) Explain the algorithm of Bays classifies.

OR

- 5) a) Explain XOR problem.  
b) Discuss back propagation algorithm.

## UNIT - III

- 6) a) Explain generalized RBF networks.  
b) Discuss properties of RBF networks.

OR

- 7) Write explanatory notes on Regularization theory and networks.

## UNIT - IV

- 8) a) Explain SOM algorithm.  
b) Discuss how ANN is used in pattern classification.

OR

- 9) Write short notes on:  
a) Contextual maps.  
b) Associative memories.

